

TCRID-1



OPERATIONS MANUAL



TABLE OF CONTENTS

INSTALLATION PREPARATION.....	2
Parts Supplied.....	2
Accessories.....	2
Installation Overview.....	2
Alternative Transducers and Mounting Methods.....	4
Transducer Exchange.....	5
INSTALLATION.....	6
Transom Installation.....	6
Inside the Hull Installation.....	10
Control Head Installation.....	12
Test the Installation.....	15
FEATURES AND FUNCTIONS.....	16
USING THE TCR ID-1.....	17
How Sonar Works.....	17
Built-In Simulator.....	19
Reading the TCR ID-1 Screen.....	20
Functions.....	23
SPECIFICATIONS.....	27
MAINTENANCE AND WARRANTY.....	28
Maintenance.....	28
Troubleshooting.....	29
Warranty.....	32
Service Policy.....	33
Customer Support.....	34

TRANSDUCER MOUNTING PROCEDURE

Humminbird's high-speed transducer is supplied with your LCR. This transducer has been designed to give good high speed readings on most all boat designs, including aluminum.

Please carefully consider the following before installing your transducer.

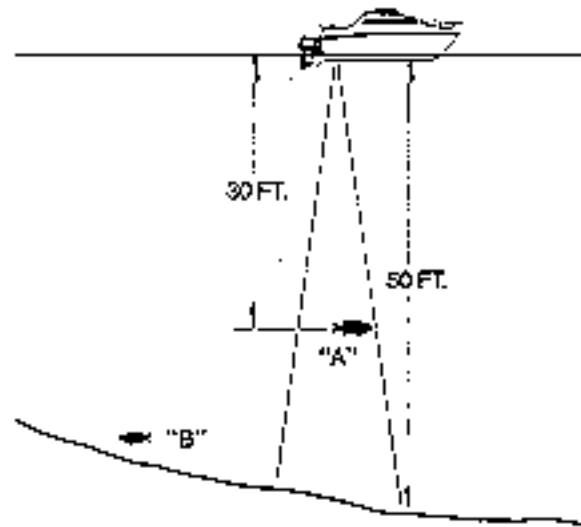
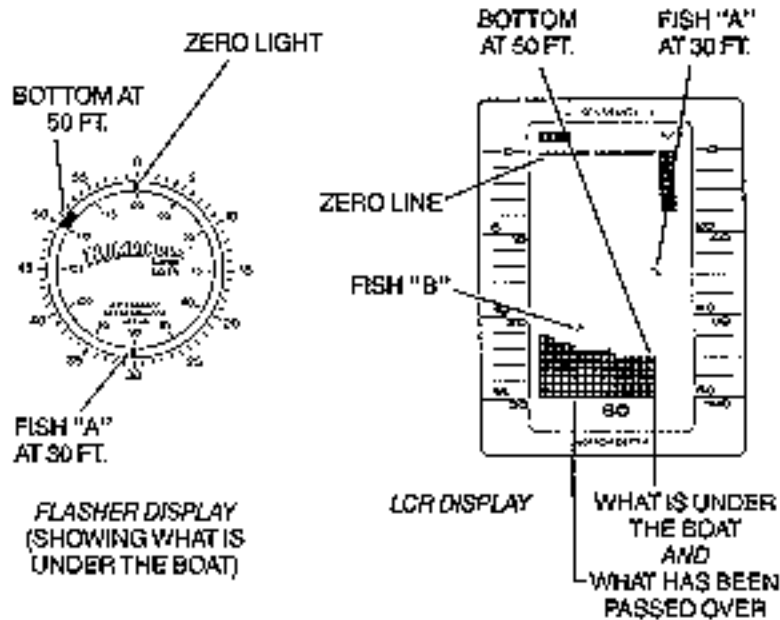

FIGURE 1

TRANSDUCER MOUNTING OPTIONS

A. Transom Mount- The Humminbird high speed transducer allows the transducer element to be mounted below the bottom of the boat hull keeping the transducer out of turbulent water and insuring good high speed operation. The transducer will

absorb the blow of any obstruction by rotating up out of the metal spring bracket without harming the transducer, or your boat. The transducer can be re-engaged by simply rotating the transducer down and snapping it back in place. (See Figure A)

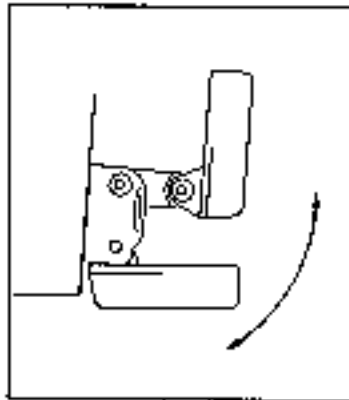

Figure A

- B. Inside Hull Mount- The high speed transducer can be mounted inside the hull (without pivot assembly) using the proper two-part epoxy, such as Humminbird's epoxy kit. Even though there is some loss of signal in shooting through the hull, your LCR will perform well with this type of installation. You cannot shoot through the hull of an aluminum boat.
- C. Trolling motor Mount- This type of transducer is not supplied with your LCR. It is designed to mount on the foot of a trolling motor. You may exchange your un-used high speed transducer for a trolling motor transducer. Call the Humminbird Customer Service Department.
- D. Bronz Thru-Hull Mount- This transducer is not supplied with your LCR but for an additional cost you may exchange your un-used high speed transducer for a bronz thru-hull. The bronz thru-hull transducer has a threaded stem which installs through a hole drilled in the boat hull, leaving the housing exposed under the boat. This type of installation must be used for many boats with in-board engines, because there is no suitable location on the transom away from the noise and turbulence created by the prop. A bronz thru-hull transducer should be installed by qualified personnel only.

The LCR will operate well at high speeds with a properly mounted transducer. Remember, a transducer will not work transmitting through air or through air bubbles.

1. TRANSOM MOUNTING PROCEDURE

Step 1.

MOUNTING LOCATION- It is important that the transducer be mounted on the transom where water flow is in constant contact with the transducer. You may wish to observe the rear of the boat while it is moving through the water to determine the best mounting location.

Step 2.

BRACKET INSTALLATION (Aluminum Boats)- To install the metal bracket on an

aluminum boat locate the template on the transom between rows of rivets, or ribs that are on the bottom of the boat. Align the template so that the bottom corner of the template nearest the center of the transom is on the bottom edge of the transom.

Figure B

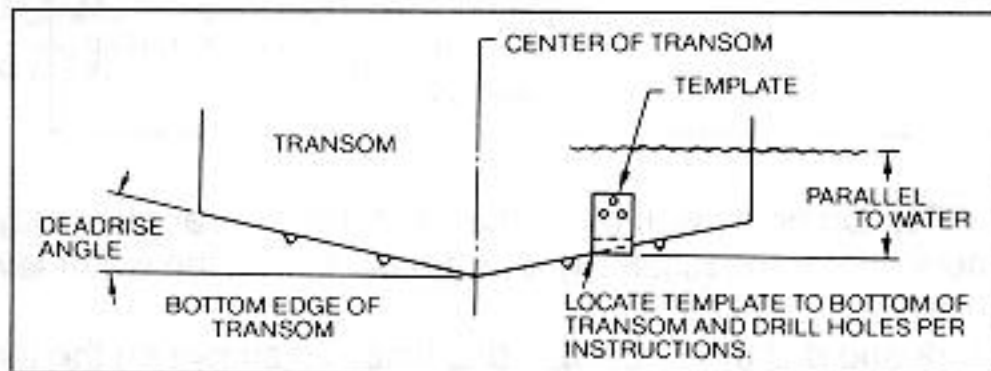

Once the location is determined mark and drill three 7/64" dia.. holes noted on the template. Attach the metal bracket using three #10 self threading screws supplied. Be sure to align holes in the center of the Bracket slots. On some aluminum boats it may be necessary to use a wood back-up plate. It is important to use a silicone sealant between the screwhead and bracket in order to prevent leaking. (See Figure C)

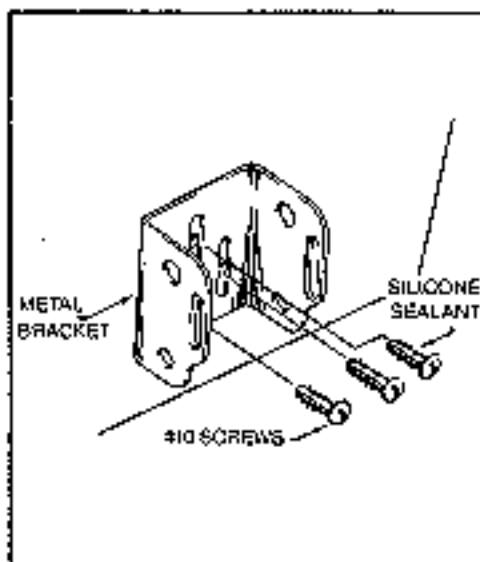

Figure C

Step 2.

BRACKET INSTALLATION (Fiberglass Boats)- If your boat has a stepped transom located below and under the main transom, the compact transducer design allows mounting in this area. This mounting location is recommended for good reading at very high speeds. (See Figure D)

To install the metal bracket on a fiberglass boat, locate the template on the transom in the same manner as for an aluminum boat. (See Figure C)

Figure D

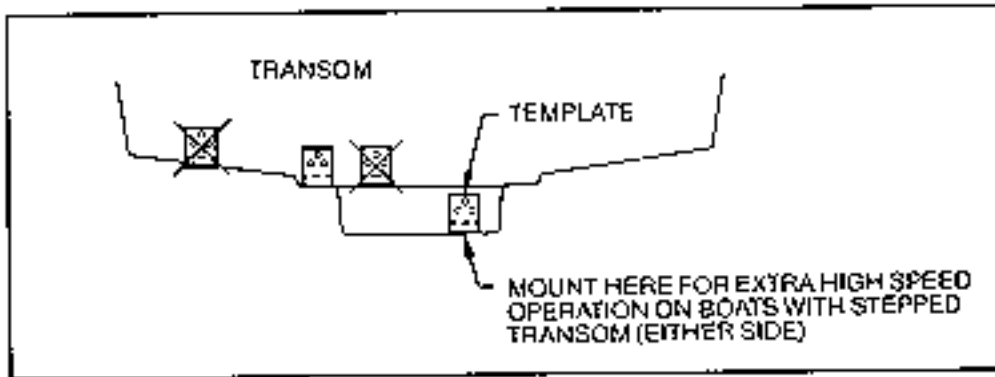

NOTE: On boats with more than 15 degree deadrise angle it may be necessary to mount the transducer slightly off parallel with the water level. (See Figure E)

Mark and drill the three 9/64" dia. holes as shown on the template. Attach the metal bracket using the three #10 self threading screws supplied. Be sure to align the holes so that they are centered vertically in the three slots found in the bracket. It is important to use a silicone sealant between the screwhead and bracket in order to prevent leaking.

Figure E

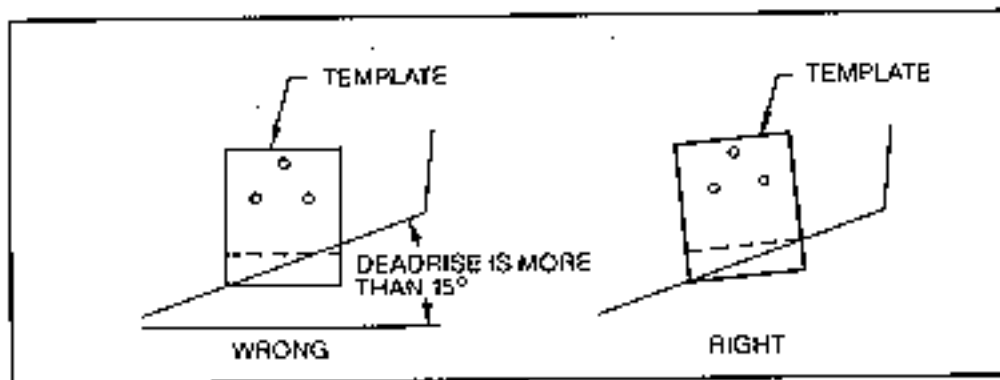

Step 3.

TRANSDUCER PIVOT ASSEMBLY- Assemble the pivot to the transducer main body using the two 1/4"x5/8" allen head screws, two 3/8" tooth washers and two, 1/4" square nuts. Make sure the tooth washers are sandwiched between the transducer main body and the pivot. The square nuts are trapped inside the pivot and will not rotate as the allen head screws are tightened. HOWEVER, DO NOT TIGHTEN AT THIS POINT. (See Figure F)

CAUTION: DO NOT APPLY LOCTITE® OR SIMILAR LOCKING COMPOUNDS BECAUSE THEY WILL ATTACK THE PLASTIC.

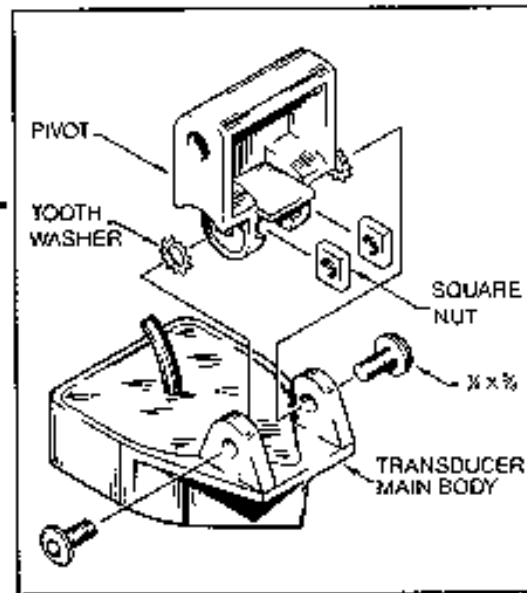

Figure F

Step 4

TRANSDUCER ASSEMBLY- Insert the transducer assembly into the metal bracket from the bottom. Push up until the holes in the plastic pivot align with the uppermost holes in the bracket. Slide the O-ring on to the headed pin and insert it through the two parts. Assemble by screwing the 1/4"x3/8" allen head screw into the end of the pin and tighten. (See Figure G)

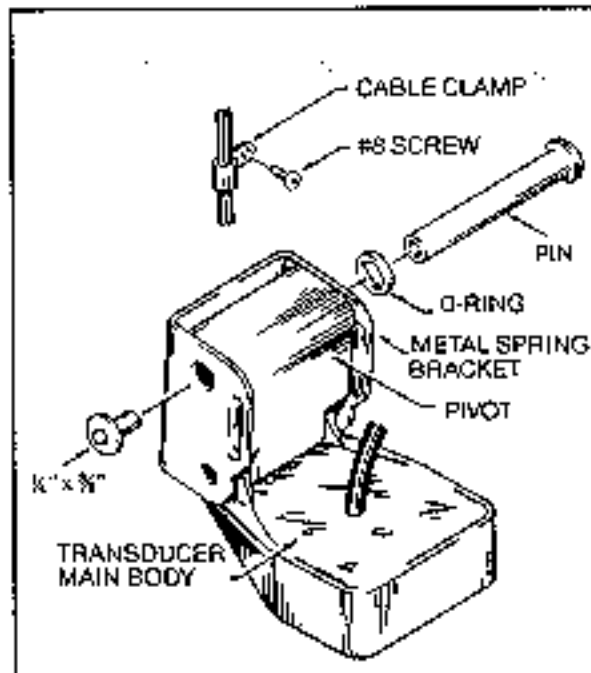

Figure G

Step 5

ANGLE ALLIGHMENT- Set the transducer angle so that it is parallel with the bottom of the boat hull. Once proper alignment is achieved, tighten the two allen head screws

using the 5/32" allen wrench provided. The screws are visible through the access holes on each side of the metal bracket. Check to make sure the transducer main body is rigidly fastened to the pivot. (See Figure H)

Figure H

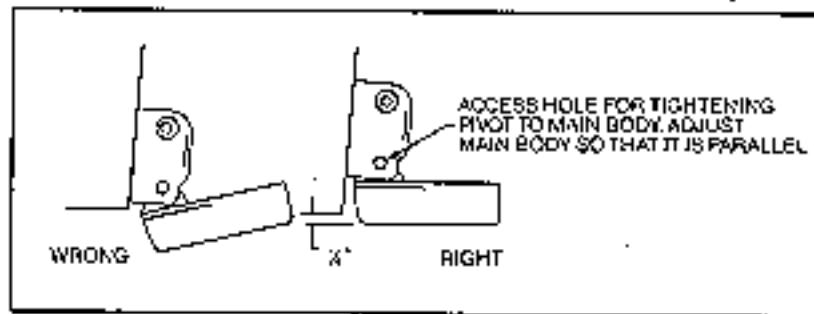

Step 6

CHECK POSITION OF TRANSDUCER- At this point, check to see that the bottom of the transducer is a minimum of 1/4" below the bottom of the transom. (However, as noted in STEP 2, the top of the transducer cannot fall below the bottom of the transom). If it is not, remove the transducer assembly from the metal bracket by removing the pin installed during STEP 3. Loosen the metal bracket mounting screws, re-position the bracket utilizing it's slotted holes, tighten and re-assemble. It may be necessary to replace the silicone sealant after this adjustment is made.

NOTE: It may be necessary to make several high speed runs to adjust transducer either UP/DOWN or to re-adjust the angle to achieve optimum results.

Step 7

CABLE CLAMPS- Install cable clamps as necessary by drilling a 1/8" dia. hole for the # 8 screw supplied.

2. INSIDE HULL MOUNTING PROCEDURE

Warning: In order to achieve proper results with this type installation, it is important that the transducer be mounted by someone familiar with the use of two part epoxy adhesives. For this reason, Techsonic Industries, Inc. will not be responsible for any damage due to the mounting of your transducer in this manner.

NOTE: An Epoxy Kit (Part N. EPK) is available from Humminbird. This Epoxy Kit has been formulated for Inside Hull Transducer Installation.

1. Select as flat an area as possible near the aft end and center of boat where the hull is thin and not double. If the bottom has a runner down the center of boat, select an area to one side of the runner, but as close to the runner as possible.
2. Clean the inside of the boat with lacquer thinner in the area transducer is to be mounted. Outside of boat in this area should also be cleaned. (Not with lacquer thinner).
3. Put approximately one inch of water in the bottom of the boat.

4. Put transducer in the water. The bottom of the transducer should be in a flat area and should be in good contact with the bottom of the boat.
5. Operate the LCR with the boat operating at high speed. The transducer may have to be moved in order to find an area where satisfactory operation is observed.
6. When an area is found that produces satisfactory operation, mark the location of the transducer.
7. Remove the water and transducer and clean the marked area and the bottom of the transducer thoroughly.
8. Using the Humminbird Epoxy Kit or equivalent, mix an ample amount of epoxy without causing it to bubble and pour it in the area the transducer is to be mounted. The puddle should be larger than the bottom of the transducer.
9. Coat the bottom of the transducer with epoxy, then put it in the center of the puddle and push down on the transducer while moving it around in a circular motion. This forces out any air bubbles that may be trapped between the bottom of the transducer and the hull of the boat.
10. Let epoxy cure then the transducer is ready to operate. No water is now required in the bottom of the boat and gas and oil that is spilled inside of the boat will not degrade performance as it will if the transducer is placed only in water.
CAUTION: Do not use the silicone seal or any soft adhesive to bond the transducer to the hull. This will reduce the sensitivity of the unit.

CAUTIONS

1. Occasionally the “eye“ of your transducer may become dirty from storage or from contact with oils present in boats or marina environments. (Oil will cause the “eye” to lose the intimate contact with the water which is necessary for efficient operation.) The “eye” may be cleaned with liquid detergent.
2. Improper installation of the transducer can alter the efficiency and accuracy of the entire system.
3. If your boat or transducer is out of the water for a period of time, it may take a short period of time for the transducer to become thoroughly “wetted” when returned to the water. Also, re-entry may cause turbulence, which will create air bubbles in the “eye” of the transducer. The bubbles will disappear in a short time or can be removed by rubbing the transducer “eye” with your fingers while the transducer is in the water.
4. If your instrument should fail to function, be sure to check all the electrical connections before removing the transducer or calling a serviceman.
5. Inspect your transducer cable and make sure that it has not been cut or damaged to the point where it will affect the performance of the transducer. A slight nick or cut, exposing the outer cable, can be repaired by wrapping with electrical tape. A transducer can be damaged if the inner cable and outer cable are allowed to make contact. Such a problem can sometimes be corrected by properly splicing the coaxial cable. This should only be attempted by a qualified service technician.
6. If your LCR is not working properly and you suspect the problem might be in your transducer, we would recommend you borrow a unit from a friend and try it on your boat. If the symptoms are the same, you can almost be certain that the problem is in the transducer.

INSTALLING THE LCR

The LCR should be mounted on a flat, solid surface for maximum stability. The low profile swivel mount has four holes drilled in the base. It is recommended that all four holes be used.

Position the swivel base and drill four ¼" diameter holes. Note: The LCR hole pattern is the same as for all Humminbird flasher units. Use hardware provided to mount this base to the boat.

Next place the gimbal bracket on the swivel base and attach with four small machine screws, provided.

Place the LCR in the gimbal mount and make certain the rubber washers provided are placed between the unit and the gimbal bracket. Important: Note which side of the gimbal faces forward. (Slots on gimbal bracket go towards rear). Also, rubber washer must be located between the unit and the gimbal bracket.

Install the mounting knobs and tighten snugly. The unit can now be swiveled and tilted to any desired position.

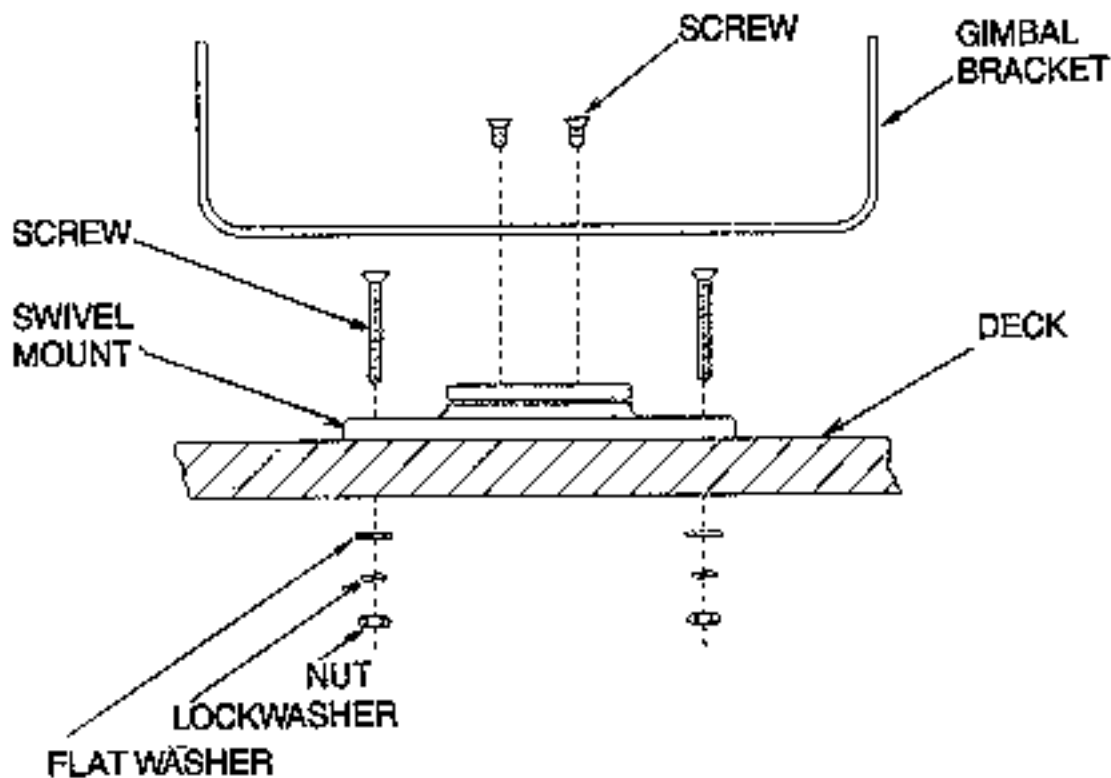

FIGURE 9

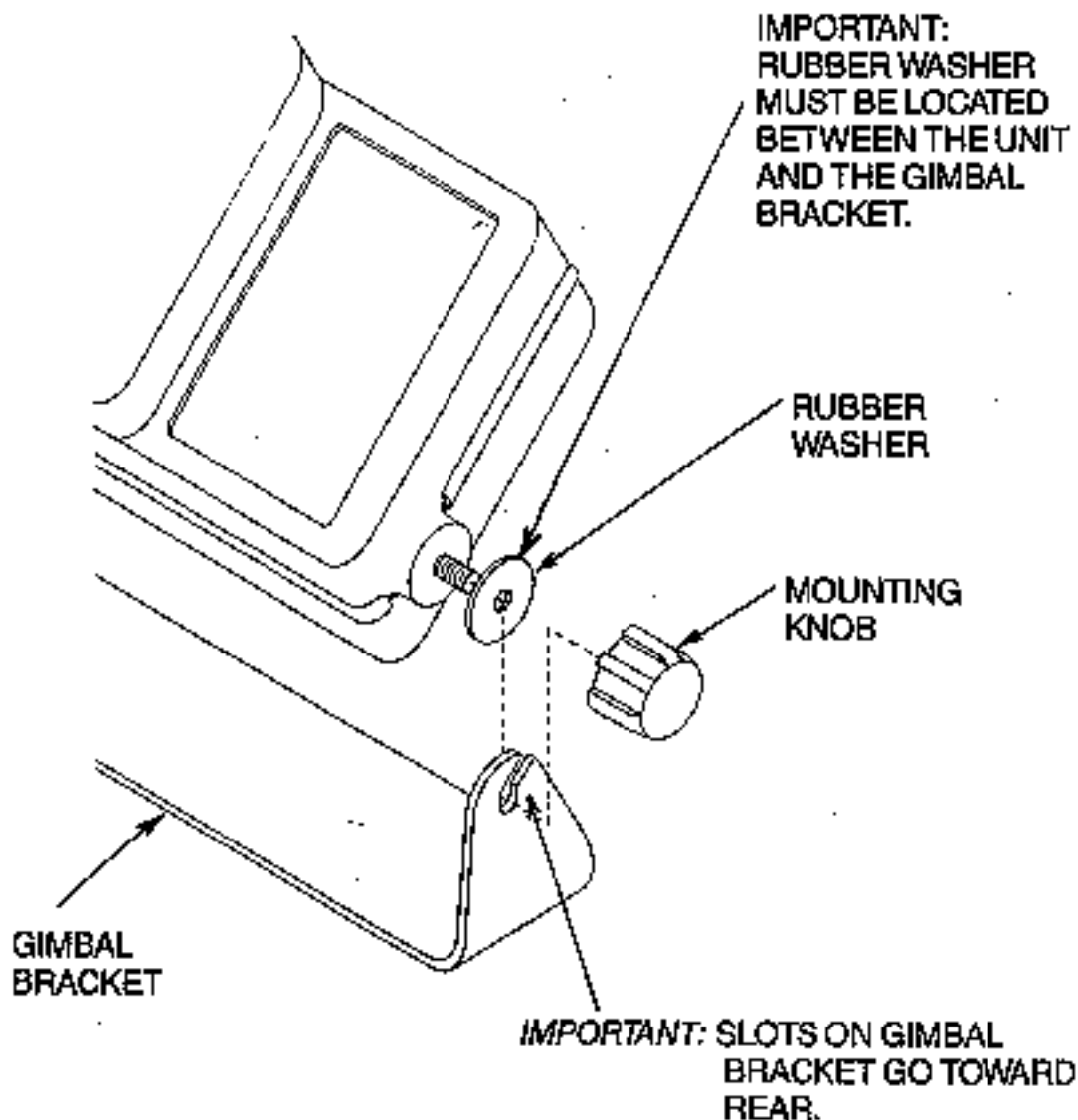

FIGURE 10

OTHER MOUNTING OPTIONS

1. The LCR gimbal bracket can also be mounted on the SM-4, quick disconnect swivel mount.
2. The LCR gimbal bracket can also be mounted directly to the dash without the swivel mount, however, this method is not recommended since the unit cannot be rotated.

INSTALLING THE CABLES

Your LCR comes equipped with Humminbird's new Angle-Lock power and transducer connectors. The power connector is identified with the letter P on the back of the plug. It plugs into the outlet on the back of the unit marked "Power". The transducer connector is identified with the letter T and plugs into the outlet on the back of the unit marked

“Transducer”. Note: An adapter (AD-4) is available to allow use of an old waterproof (BNC) transducer with the LCR, but be sure that the transducer is a 16degree. A 32-degree transducer cannot be used.

A 1 1/8” hole must be drilled to pull through the transducer connector. After drilling the hole, pull the transducer connector up through the hole. If you are installing two units, both transducer connectors can be pulled through this 1 1/8” inch hole. Next, push the power cable wires down through the hole. A hole cover has been provided which will dress and hold the wires. Install the hole cover after determining the necessary wire length from the hole.

The power cable has a red lead to the positive (+) post and the black lead to the negative (-) post. Install a 1 amp fuse between the red cable and positive post of your 12-volt battery.

If a fuse panel is available, we recommend wiring the power cable into the fuse panel.

Note: The LCR must be fused separately from any other accessory.

Your Angle-Lock connectors can only be plugged in one way. Position the connector so the letter P or T can be read and the 90 degree bend is pointed downward. Push the connector in as far as it will go. Turn the positive locking ring as far as it will go clockwise until you feel it lock. Locking ring as far as it will go clockwise until you feel it lock. Your connector is now locked into place.

Note: For easy access to the connectors, simply loosen the mounting knobs and tilt your LCR forward. The connectors are now in full view and easy to plug or unplug.

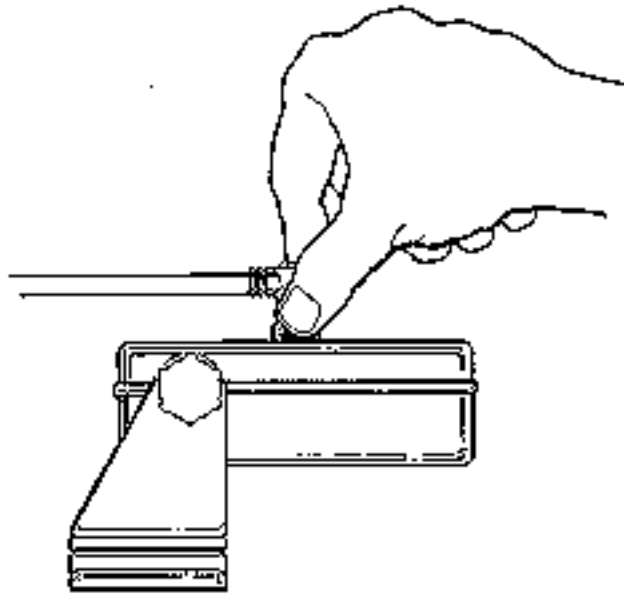

INSTALLATION

TEST THE INSTALLATION

TEST THE INSTALLATION

Testing should be performed with the boat in the water, however you can initially confirm basic operation with the boat trailered.

Press POWER once to turn the unit on. There will be an audible chirp when any button is pressed to confirm the button press. If the unit does not power-up, ensure the unit is fully seated on the mount and that power is available.

The first screen provides four options: Start-up, Options, Simulator, and Diagnostic. A message at the bottom of the screen indicates the transducer connection. If no transducer is detected (or one is not connected), the message will indicate this and the unit will go into simulator after the initial screen times out.

Note: the transducer must be submerged in water for reliable transducer detection.

If a transducer is detected, the unit will enter "Start Up" or normal operation unless you choose another option. If you do not press any button before the timer reaches "0", the normal operation screen is displayed. If the boat is in water, sonar data appears.

If the bottom is visible on screen with a digital depth readout, the unit is working properly. Ensure the boat is in water greater than 2' but less than the depth capability of the unit and the transducer is fully submerged. Remember the sonar signal cannot pass through air.

If the unit is working properly gradually increase the boat speed to test high-speed performance. If the unit-functions well at low speeds but begins to skip or miss the bottom at higher speeds, the transducer requires adjustment. Refer to the appropriate transducer installation section for more detail.

Note: it is often necessary to make several incremental transducer adjustments before optimum high-speed performance is achieved.

Important: For Transom Mount transducer installations, install the third mounting screw after the final transducer adjustments.



USING THE TCR ID-1

FEATURES AND FUNCTIONS

TCR ID-1

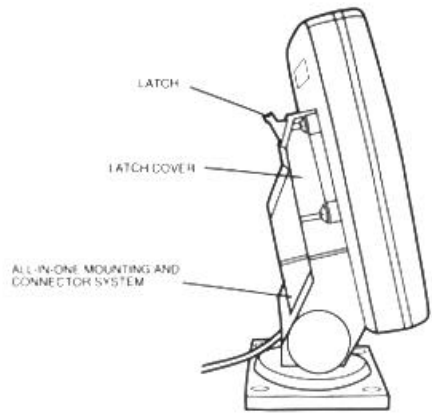
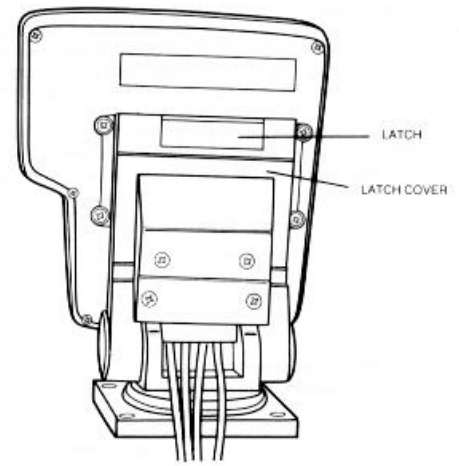

USING THE TCR ID-1

HOW SONAR WORKS

HOW SONAR WORKS

Humminbird depth sounders work on the basic principles of sonar. An electronic signal generated in the unit is changed to an ultrasonic signal by the transducer or Sensor, which sends the signal toward the bottom. The signal travels downward until it strikes either the bottom or an object above the bottom. Then, signals or echoes bounce back to the Sensor, which receives them and changes them back to electronic signals that can be displayed on the unit's screen.

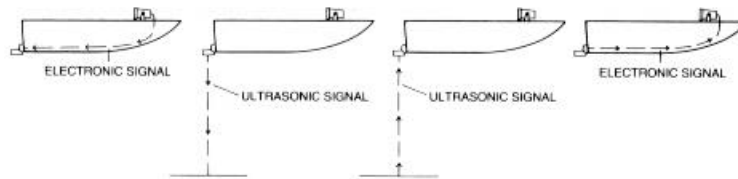

Why 455KHz?

Deepwater depth sounders have long used 50KHz for best deepwater performance, but they suffer with poor definition. Shallow-water units use a higher frequency 200KHz system for better target separation and detail. But TCR technology takes high definition to a new level with its exclusive 455KHz operation.

What does that mean to the fisherman? TCRs have twice the frequency, three times the power (1600 watts, peak to peak) and twice the detail of other units. You can clearly separate fish from the bottom and from structure, and you can see individual fish in a way that ordinary depth sounders just can't show them. Quite simply you see more fish with more detail!

WHAT IS A HIGH-DEFINITION DEPTH SOUNDER?

The TCR ID-1 features our exclusive 455KHz high-definition performance system - twice the frequency, three times the power (1600 walls peak to peak) and twice the detail of other units.

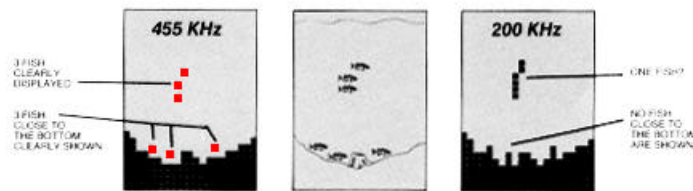

USING THE TCR ID-1

HOW SONAR WORKS

Compact, High-Definition Sensor.

To send and receive this higher-frequency signal, we developed a new High-Definition Sensor. You can immediately see the difference between our 455KHz Sensor and older 200KHz transducers. This unique new Sensor makes bulky low-definition transducers a thing of the past.

Our new Sensor is so compact, it's a snap to install. It's designed for superior high-speed performance, and because of its small size you'll have less problem with drag, turbulence, or rooster-tails. This new Sensor is actually less likely to be damaged by debris, yet performs with all the accuracy you expect from Humminbird.

USING THE TCR ID-1

BUILT-IN SIMULATOR

BUILT-IN SIMULATOR

To help you learn to use your new unit, Humminbird has built a simulator into the TCR ID-1. The simulator will display a typical underwater scene, and allow you to use the controls for practice.

Activating the simulator is easy - with the unit turned off, hold down the power button for about 2 seconds, until a chirping sound begins. When you release the button, the built-in simulator will be on and ready for your practice session. Turning your unit off and back on again will disengage the simulator, for operating the TCR ID-1 in actual conditions.

NOTE: The built-in simulator will allow you to practice adjusting the sensitivity, but your adjustments will not change the readings being displayed on the screen.

USING THE TCR ID-1

READING THE TCR ID-1 SCREEN

READING THE TCR ID-1 SCREEN

Your TCR has a liquid crystal display, or LCD. The liquid crystal material in the display aligns itself to either block light or let light pass through. This blocking of light creates images on the screen. Since the display depends on light to form its images, increasing the light source makes it easier to see. This is why your TCR can be seen so well in bright, direct sunlight.

You will also notice that the display can be seen better at certain angles. The TCR mounting system has been designed for tilting and pivoting so that you can easily maintain a good angle for viewing. Another characteristic of the display is that some polarized glasses can affect your view by causing a rainbow or prism to appear. This can be improved by slightly tilting the unit.

Fish Identification

The TCR ID-1 uses Humminbird's exclusive double-layer LCD. Ordinary LCD units have 2 colors - black and white. But the TCR ID-1 adds a third color - red - by using a second layer on the display. This double-layer display gives you more information than ordinary black and white units:

1. **Objects close to the bottom are displayed in red.** The bottom and any structure attached to it are displayed in black. The microcomputer within the TCR ID-1 will detect objects close to the bottom and display them in red no matter what depth range you're in. This is especially helpful if you're bottom-fishing
2. **Stronger signals are displayed as a black dot behind a red dot.** The TCR ID-1's microcomputer also helps you identify stronger signals, such as those from larger fish, because they are displayed as a black dot behind a red dot. It's easy to separate them from the weaker returns displayed in red only.

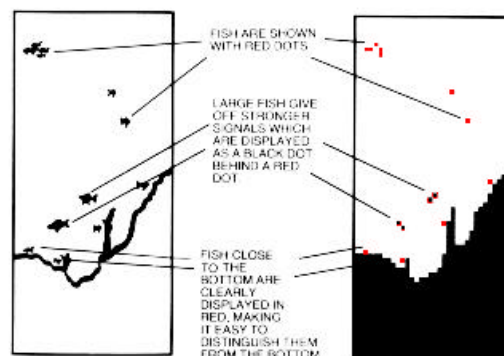

USING THE TCR ID-1

READING THE TCR ID-1 SCREEN

Total Screen Update

Humminbird's exclusive Total Screen Update instantly updates the entire TCR screen to include new information each time a function is changed no waiting for the changes to "march" onto the screen. This feature is valuable in 2 ways:

1. **Changing depth ranges.** When the depth range changes to a deeper or shallower scale, the entire screen changes to display the new depth scale. For example, if you're in the 0-60' scale and it changes to the 0-30' scale, the entire screen will look as if you had been in the 0-30' range all along.

2. **Using zoom and bottom-lock.** Through Pixel Memory Capacity, the memory in the TCR ID-1 stores readings in much finer detail than is displayed in the "regular" mode. So when you activate the zoom or bottom-lock functions, the entire screen changes to display the up-close detail that is stored in memory. Then when you turn on the zoom or bottom-lock, the whole screen will change back to the full depth scale.

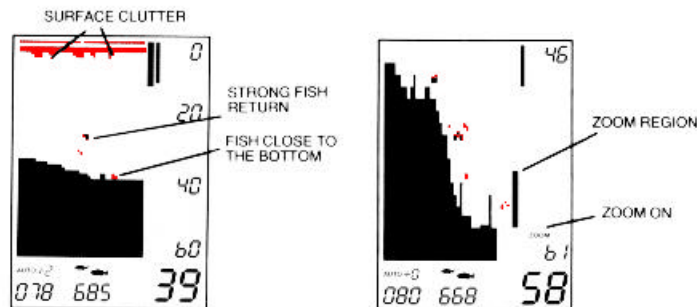
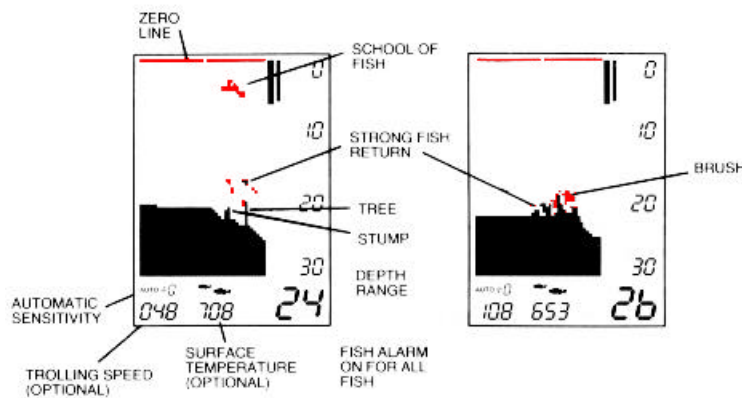

USING THE TCR ID-1

READING THE TCR ID-1 SCREEN

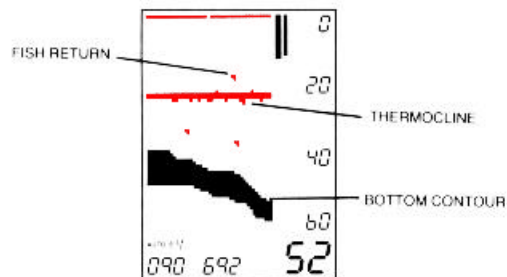
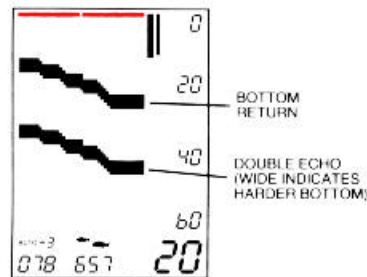
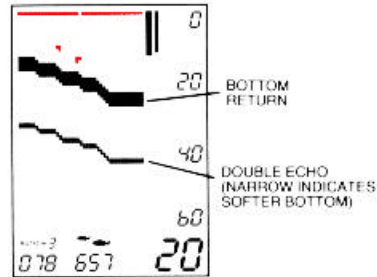

Of course, the best way to learn to read your TCR ID-1 is to use it, especially in familiar locations. If you know what's underwater and can see it displayed on the screen, then you're on your way to being an experienced TCR user.

USING THE TCR ID-1

OPERATING THE TCR ID-1

OPERATING THE TCR ID-1

Your new TCR ID-1 offers unique automatic features, as well as many adjustable ones. If you're learning to operate the TCR ID-1 with its simulator, follow the directions listed at "Built-In Simulator" on page 16, and then come back to this page. If you're learning to use your TCR ID-1 using actual on-the-water readings, proceed with the following instructions.

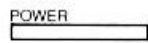

Power:

Pressing this button once turns the TCR ID-1 on. Pressing it once again turns it off. When the unit is turned off, holding this button down for about 2 seconds activates the built-in simulator.

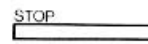

Stop:

By pressing this button once, you can stop or "freeze" the display. Pressing the button once again re-starts the display at its previous speed setting.

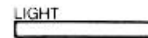

Light:

The TCR ID-1 features a 2-level backlight that evenly lights up the display from behind the screen. Pressing the "light" button once gives you a soft glow that is ideal for night fishing because it won't interfere with your night vision. Press the button again for a brighter light, making the display easy to read at dusk when it can be harder to see. Pressing the button a third time turns off the backlight.

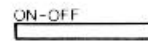
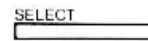

Select System:

The TCR ID-1 Select System commands an amazing number of functions with only four buttons: Select, Up and Down arrows, and On/Off.

When you press the Select button, each function appears in a block on the screen with easy-to-understand instructions for using the function. You use the Up and Down arrows and the On/Off button to adjust the functions. Then, the Instructions disappear, returning the display to its full screen reading.

Select System functions are "active"; that is, the last function displayed on the screen can be adjusted without pressing the select button again. This is valuable in 2 ways.

Example 1: Readjusting a function.

If bottom alarm was the last function used, you can adjust it again by pressing one of the arrow buttons or the On/Off button.

USING THE TCR ID-1

OPERATING THE TCR ID-1

Example 2: Often-used function.

If you think you'll be using zoom often, you can go to the zoom function, let the instructions disappear, and then activate the zoom when you need it simply by pressing On/Off.

The following describes the functions and how to use them, in order of appearance after you turn the unit on.

1. Sensitivity

Automatic setting: on, "0" or normal

As conditions change, the computer will automatically increase or decrease the sensitivity setting. You can manually increase or decrease the automatic setting from a range of "+5" to "-5." This level will maintain itself as long as you have the unit on, automatically, as a result of the TCR's Sensitivity Bias feature. For example, if you set the sensitivity at "+2," the sensitivity will remain 2 settings higher than the normal automatic settings until you turn the TCR off.

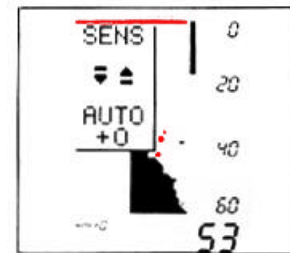

FIGURE 16

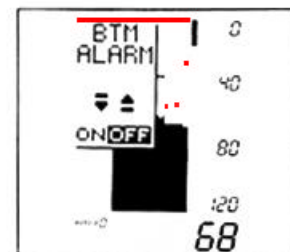

FIGURE 17

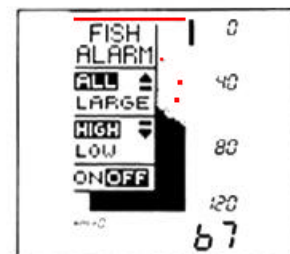

FIGURE 18

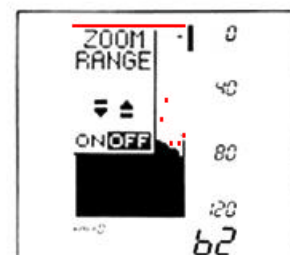

FIGURE 19

2. Bottom Alarm

Automatic setting: off

Use the On/Off button to activate the alarm, and the alarm cursor appears on the screen. Then use the arrow keys to adjust the depth at which the alarm will sound. You'll hear a continuous chirping sound when the bottom is within the area that you've defined with the alarm cursor. This is a great feature to use to alert you to shallow water, or to maintain your position over structure.

3. Fish Alarm

Automatic setting: off

The fish alarm is easily activated by pressing the On/Off button. This 2-level alarm can be set to sound for all fish, or to ignore weaker signals and alarm only for stronger signals, such as those from larger fish. You can also adjust the volume of the fish alarm.

The controls for this function are a little different. Pressing the Up arrow lets you switch between alarms for all fish and large fish. The Down arrow controls volume of the alarm.

USING THE TCR ID-1

OPERATING THE TCR ID-1

Once the instructions have disappeared from the screen, it's easy to tell which alarm you have activated - the alarm for all fish shows both small and large fish symbols at the bottom of the screen, while the "large only" alarm displays only a large fish symbol.

4. Zoom

Automatic setting: off

When zoom is activated by pressing On/Off, it creates a "window" of expanded, up-close information. This window is marked by a cursor at the right of the screen and can be moved up or down with the arrow buttons. The exact depths of the upper and lower limits of the window are displayed as depth scales while you are in zoom.

The size of the zoom window changes as the depth range changes. The window displays 7½ feet of up-close readings in the 15' and 30' ranges, and 15 feet in the 60' and 120' ranges. Keep in mind that, using your arrow buttons, you can move the zoom window while the zoom is activated, without having to press Select again.

5. Bottom-Lock

Automatic setting: off

You can easily turn on the bottom-lock with the On/Off button. When on, this function shows up-close zoom readings in reference to the bottom. The size of the zoom window depends on the depth range - 7½ feet in the 15' and 30' ranges, and 15 feet in the 60' and 120' ranges. The zoom window will automatically move up or down to stay on the bottom, with the cursor showing you the portion of the total depth range that is being displayed. This is an ideal feature for finding structure or locating fish near the bottom.

6. Display Speed

Automatic setting: one setting less than highest speed

The speed at which the TCR display moves depends on the display speed setting, and it is easily changed by pressing the Up arrow for a faster setting and the Down arrow for a slower setting. Generally speaking, the higher speed settings allow faster updates while slower display speeds provide more information.

FIGURE 20

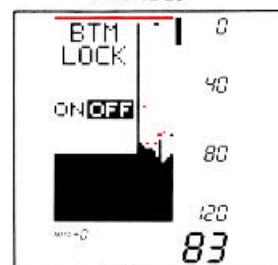

FIGURE 21

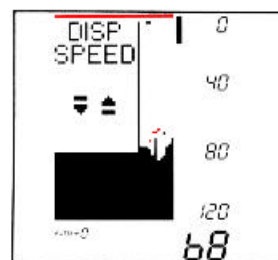
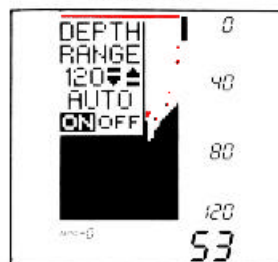

FIGURE 22



USING THE TCR ID-1

OPERATING THE TCR ID-1

7. Depth Range

Automatic setting: on

The TCR automatically finds the bottom and then sets and displays the ideal depth range when you turn the unit on. If you choose to leave the auto range change on, the bottom will remain "blacked in" for easy-to-understand readings, and the depth ranges will change automatically.

Or, you can turn the auto change off, allowing you to change the depth range manually. In this mode, the bottom is not blacked in. This lets you see a double bottom echo, which is preferred by some fishermen because the width of the second echo can indicate bottom texture (see "Reading The TCR ID-I Screen" for details on using the double echo).

SPECIFICATIONS

Operating Frequency	455KHz
Power Requirement	12 volts
Power Cable Length	11½'
Sensor (standard)	SHS-6-16 High-Definition, high-speed
Sensor Cone Angle	16 degrees
Sensor Cable Length	20'
Depth Ranges	0-15', 0-30', 0-60', 0-120'
Zoom Ranges	7½', 15'
Mounting (standard)	All-in-One Mounting & Connector System
Unit Construction	High-impact polycarbonate case
Dimensions	6 ½" W X 6 ¾"H X 1 ½"D
Display	liquid crystal
Viewing Area	3" W X 4" H
Matrix Configuration	48 x 75 pixels

MAINTENANCE AND WARRANTY

MAINTENANCE

MAINTENANCE

Your Humminbird fishfinder is designed to provide years of trouble free operation with virtually no maintenance. Follow these simple procedures to ensure your Humminbird continues to deliver top performance.

- If the unit comes into contact with salt spray simply wipe the affected surfaces with a cloth dampened in fresh water. Do not use a chemical glass cleaner on the lens. Chemicals in the solution may cause cracking in the lens of the unit.
- When cleaning the LCD protective lens, use a chamois and non-abrasive, mild cleaner. Do not wipe while dirt or grease is on the lens. Be careful to avoid scratching the lens.
- If your boat remains in the water for long periods of time, algae and other marine growth can reduce the effectiveness of the transducer. Periodically clean the face of the transducer with liquid detergent. Pivoting the transducer up in the bracket may allow better access for inspection or cleaning.
- If your boat remains out of the water for a long period of time, it may take some time to wet the transducer when returned to the water. Small air bubbles can climb to the surface of the transducer and interfere with proper operation. These bubbles dissipate with time, or you can wipe the face of the transducer with your fingers after the transducer is in the water.
- Never leave the fishfinder in a closed car or trunk - the extremely high temperatures generated in hot weather can damage the electronics.

MAINTENANCE AND WARRANTY

TROUBLESHOOTING

TROUBLESHOOTING

Do not attempt to repair the fishfinder yourself. There are no user serviceable parts inside, and special tools and techniques are required for reassembly to ensure the waterproof integrity of the housing. Repairs should be performed only by authorized Humminbird technicians.

Many requests for repair received by Humminbird involve units that do not actually need repair. These units are returned "no problem found." If you have a problem with your Humminbird, use the following troubleshooting guide before calling Customer Support or sending your unit in for repair. Your Humminbird fishfinder contains several tools that can aid in determining if there is a problem and how to isolate and repair the problem in many cases.

1. *Nothing happens when I turn the unit on.*

Check the power cable connection at both ends. Be sure the cable is connected correctly to a reliable power source - red lead to positive, black lead to negative or ground. Ensure the power available at the mount is between 10 and 20 VDC. If the unit is wired through a fuse panel, ensure the panel is powered. Often accessory fuse panels are controlled by a separate switch or the ignition switch. Also, often a fuse can appear to be good when in fact it is not. Check the fuse with a tester or replace it with a fuse known to be good.

Check the power connection to the unit. It is possible to force the power cable connector into the cable holder incorrectly. If the connector is reversed, the unit will not work. Examine the contacts on the back of the unit to ensure there is no corrosion. Finally, ensure the unit is firmly seated on the mount. The electrical contacts are not made until the unit is fully seated.

Ensure the metal cable retainer is properly installed in the mount. If not, the power connected may push out when the unit is put on the mount.

2. *There is no transducer detected.*

Most Humminbird fishfinders have the ability to detect and identify that a transducer is connected. If at power up, a message indicates "transducer not connected," only simulator operation is possible. First, ensure that an appropriate transducer connector is positioned correctly in the connector holder, and that the unit is fully seated on the mount. Your Humminbird fishfinder will work only with an appropriate transducer; check the accessory guide for compatibility.

MAINTENANCE AND WARRANTY

TROUBLESHOOTING

Second, inspect the transducer cable from end to end for breaks, kinks, or cuts in the outer casing of the cable. Also ensure the transducer is fully submerged in water. If the transducer is connected to the unit through a switch, temporarily connect it directly to the unit and try again. If none of these items identifies an obvious problem, the transducer itself is probably the problem. Be sure to include the transducer if returning the unit for repair.

3. There is no bottom reading visible on the display.

There are a number of possible causes for this condition. If the loss of bottom information occurs only at high boat speeds, the transducer needs adjusting. If the digital depth readout is working but there is no bottom visible on-screen, it is possible the depth range has been adjusted manually to a range lower than what is needed to display the bottom. Also, in very deep water, it may be necessary to manually increase the sensitivity setting to maintain a graphic depiction of the bottom.

If you are using a transducer switch to connect two transducers to the unit, ensure the switch is in the correct position to connect a transducer that is in water. (If a trolling motor transducer is selected and the trolling motor is out of water, no sonar information appears.)

If none of the above solve the problem, inspect the transducer cable from end to end for breaks, kinks, or cuts in the outer casing of the cable. If the transducer is connected to the unit through a switch, temporarily connect it directly to the unit and try again. If none of these items identifies an obvious problem, the transducer itself may be the problem. Be sure to include the transducer if returning the unit for repair.

4. When in very shallow water, I get gaps in the bottom reading and inconsistent digital depth indication.

Your Humminbird fishfinder will work reliably in water 2' (.6m) or deeper. The depth is measured from the transducer, not necessarily from the surface.

MAINTENANCE AND WARRANTY

TROUBLESHOOTING

5. *The unit comes on before I press POWER, and won't turn off.*

Check the transducer cable. If the outer jacket of the cable has been cut and the cable is in contact with bare metal, you need to repair the cut with electrical tape. If there is no problem with the cable, disconnect the transducer from the unit and see if the problem is corrected, to confirm the source of the problem.

6. *I get gaps in the reading at high speeds.*

Your transducer needs adjusting. If the transducer is transom-mounted, there are two adjustments available to you - height and running angle. Make small adjustments and run the boat at high speeds to determine the effect. It may take several tries to optimize high speed operation. This can also be a result of air or turbulence in the transducer location caused by rivets, ribs, etc.

7. *My unit loses power at high speeds.*

Most Humminbird fishfinders have over-voltage protection that turns the unit off when input voltage exceeds 20 VDC. Some outboard motors do not effectively regulate the power output of the engine's alternator and can produce voltage in excess of 20 volts when running at high RPMs. Your fishfinder displays input voltage in the Diagnostic screen. Use this readout to determine if the voltage exceeds 20 VDC.

8. *The screen begins to fadeout. Images are not as sharp as normal.*

Check the input voltage using Diagnostic. The fishfinder will not operate on input voltages below 10 VDC.

9. *The display shows many black dots at high speeds and high sensitivity settings.*

You are seeing noise or interference caused by one of several sources. Noise can be caused by other electronic devices. Turn off any nearby electronics and see if the problem goes away. Noise can also be caused by the engine. If engine noise is causing the interference, the problem will intensify at higher RPMs. Increase the engine speed with the boat stationary to isolate this cause. Propeller cavitation can appear as noise on-screen. If the transducer is mounted too close to the propeller, the turbulence generated can interfere with the sonar signal. Ensure that the transducer is mounted at least 15" (38cm) from the prop.

MAINTENANCE AND WARRANTY

WARRANTY

HUMMINBIRD ONE YEAR FULL WARRANTY

First year repairs (from original date of purchase) on your Humminbird fishfinder are absolutely free. This does not include physical damage to the unit or its accessory items. Any modification or attempt to repair the original equipment or accessories by unauthorized individuals will void the warranty. Return the warranty registration card and retain your bill of sale for warranty verification. Accessories not manufactured under the Humminbird trade name are not covered by our warranty. **The customer is responsible for shipping charges to Humminbird.** Humminbird will provide ground UPS or Parcel Post shipping back to the customer free of charge. This warranty applies to the original purchaser only.

This warranty is in lieu of all other warranties expressed or implied and no representatives or persons are authorized to provide for any other liability in connection with the sale of our products. Humminbird reserves the right to perform modifications or improvement on its products without incurring the obligation to install the changes on units previously manufactured, sold, delivered, or serviced.

THIS IS A FULL WARRANTY AS DEFINED BY THE FEDERAL WARRANTY ACT EFFECTIVE JULY 4 1975.

MAINTENANCE AND WARRANTY

SERVICE POLICY

SERVICE POLICY

This Service Policy is valid in the United States only. This applies to Humminbird units returned to our factory in Eufaula, Alabama, and is subject to change without notice.

All repair work is performed by factory-trained technicians to meet exacting factory specifications. Factory serviced units go through the same rigorous testing and quality control inspection as new production units.

Even though you'll probably never need to take advantage of our incredible service guarantee, it's good to know that we back our unit this well. We do it because you deserve the best. We will make every effort to repair your unit within three working days from the receipt of your unit. This does not include shipping time to and from our factory. Units received on Friday are usually shipped by Wednesday, units received Monday are usually shipped by Thursday, etc.

We reserve the right to deem any product unserviceable when replacement parts are no longer reasonably available or impossible to obtain.

After the original warranty period, a standard flat rate service charge will be assessed for each repair (physical damage and missing parts are not included). Please call our Customer Support Department to verify the service charge for your unit.

The standard service charge includes UPS or Parcel Post freight only. If charges are not prepaid, the unit will be returned COD. If you are experiencing problems related to bottom or depth readings please send your transducer along with your unit when sending for repair.

MAINTENANCE AND WARRANTY

CUSTOMER SUPPORT

CUSTOMER SUPPORT

If you have any questions, call our
Humminbird Customer Support Hotline: **1-334-687-0503**

Throughout the U.S. and Canada, hours are Monday-Friday, 8:00 a.m. to 5:00 p.m.
Central time.

If after reading "Troubleshooting" you determine your unit needs factory service, please
attach a description of the problem and send it with the unit to the address below.

If you are including a check please attach it to the unit.

**Humminbird
Service Department
Three Humminbird Lane
Eufaula, AL 36027
USA**